

100Gb/s QSFP28 LR4 10km Transceiver HX4X-CL311x

Features

- Compliant with 100GBASE-LR4
- Supports 103.1Gb/s aggregate bit rate
- Integrated LAN WDM TOSA / ROSA for up to 10 km reach over SMF
- 4x25G electrical interface (OIF CEI-28G-VSR) and 4-lane 25.78Gb/s optical interface
- Duplex LC optical receptacle
- Support Digital Monitoring interface
- No external reference clock
- RoHS-10 compliant and lead-free
- Compliant with QSFP28 MSA with LC connector
- Single +3.3V power supply
- Maximum power consumption 3.5W
- All-metal housing for superior EMI performance
- Case operating temperature
Commercial: 0 ~ +70°C
Extended: -10 ~ +80°C
Industrial: -40 ~ +85°C

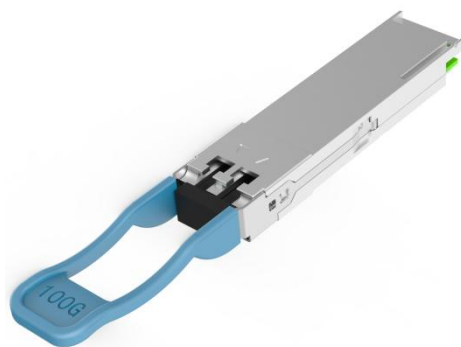

Applications

- Data Center
- Local Area Network (LAN)
- Ethernet switches and router applications

Part Number Ordering Information

| Part Number | Data Rate (Gb/s) | Wavelength (nm) | Transmission Distance(km) | Temperature (°C) (Operating Case) |
|-------------|------------------|------------------------------------|---------------------------|-----------------------------------|
| HX4X-CL311C | 103.1 | 1295.56, 1300.05, 1304.58, 1309.14 | 10 | 0~70 commercial |
| HX4X-CL311E | 103.1 | 1295.56, 1300.05, 1304.58, 1309.14 | 10 | -10~80 Extended |
| HX4X-CL311I | 103.1 | 1295.56, 1300.05, 1304.58, 1309.14 | 10 | -40~85 Industrial |

I. Absolute Maximum Ratings

It has to be noted that the operation in excess of any individual absolute maximum ratings might cause permanent damage to this module.

| Parameter | Symbol | Min | Max | Unit | Notes |
|--------------------------------------|-----------------|------|-----|------|-------|
| Storage Temperature | T _S | -40 | 85 | °C | |
| Power Supply Voltage | V _{CC} | -0.3 | 4.0 | V | |
| Relative Humidity (non-condensation) | RH | 5 | 95 | % | |
| Damage Threshold | TH _d | 5.0 | | dBm | |

II. Recommended Operating Conditions

| Parameter | Symbol | Min | Typical | Max | Unit | Notes |
|----------------------------|-----------------|-------|----------|-----------------|------|------------|
| Operating Case Temperature | T _{OP} | 0 | | 70 | °C | commercial |
| | | -10 | | 80 | | extended |
| | | -40 | | 85 | | Industrial |
| Power Supply Voltage | V _{CC} | 3.135 | 3.3 | 3.465 | V | |
| Data Rate, each Lane | | | 25.78125 | | Gb/s | |
| Control Input Voltage High | | 2 | | V _{CC} | V | |
| Control Input Voltage Low | | 0 | | 0.8 | V | |
| Link Distance (SMF) | D | | | 10 | km | 9/125um |

III. General Description

Walsun'100G QSFP28 LR4 optical Transceiver integrates receiver and transmitter path on one module. In the transmit side, four lanes of serial data streams are recovered, retimed, and passed to four laser drivers. The laser drivers control 4- Distributed Feedback Laser (DFB) with center wavelength of 1296 nm, 1300nm, 1305nm and 1309 nm. The optical signals are multiplexed to a single –mode fiber through an industry standard LC connector. In the receive side, the four lanes of optical data streams are optically de-multiplexed by the integrated optical de-multiplexer. Each data stream is recovered by a PIN photo-detector and trans-impedance amplifier, retimed. This module features a hot-pluggable electrical interface, low power consumption and MDIO management interface.

The product is designed with form factor, optical/electrical connection and digital diagnostic interface according to the QSFP28 Multi-Source Agreement (MSA) and compliant to IEEE 802.3bm.

IV. Pin Assignment and Pin Description

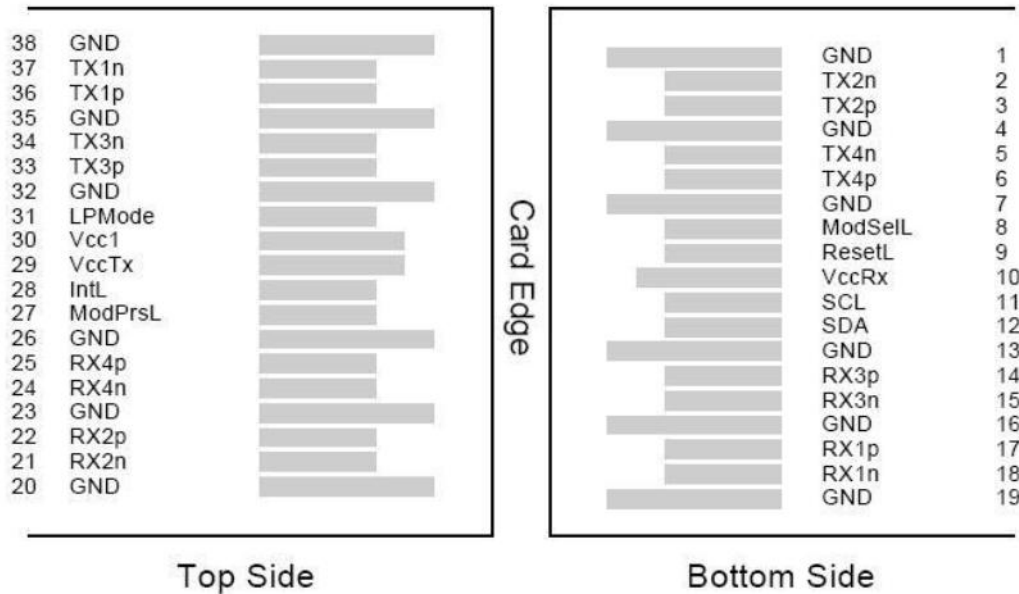

Figure1. Diagram of host board connector block pin numbers and names

| Pin | Symbol | Name/Description | Notes |
|-----|---------|--|-------|
| 1 | GND | Transmitter Ground (Common with Receiver Ground) | 1 |
| 2 | Tx2n | Transmitter Inverted Data Input | |
| 3 | Tx2p | Transmitter Non-Inverted Data output | |
| 4 | GND | Transmitter Ground (Common with Receiver Ground) | 1 |
| 5 | Tx4n | Transmitter Inverted Data Input | |
| 6 | Tx4p | Transmitter Non-Inverted Data output | |
| 7 | GND | Transmitter Ground (Common with Receiver Ground) | 1 |
| 8 | ModSelL | Module Select | |
| 9 | ResetL | Module Reset | |
| 10 | VccRx | 3.3V Power Supply Receiver | 2 |
| 11 | SCL | 2-Wire serial Interface Clock | |
| 12 | SDA | 2-Wire serial Interface Data | |
| 13 | GND | Transmitter Ground (Common with Receiver Ground) | |
| 14 | Rx3p | Receiver Non-Inverted Data Output | |
| 15 | Rx3n | Receiver Inverted Data Output | |

| | | | |
|----|---------|--|---|
| 16 | GND | Transmitter Ground (Common with Receiver Ground) | 1 |
| 17 | Rx1p | Receiver Non-Inverted Data Output | |
| 18 | Rx1n | Receiver Inverted Data Output | |
| 19 | GND | Transmitter Ground (Common with Receiver Ground) | 1 |
| 20 | GND | Transmitter Ground (Common with Receiver Ground) | 1 |
| 21 | Rx2n | Receiver Inverted Data Output | |
| 22 | Rx2p | Receiver Non-Inverted Data Output | |
| 23 | GND | Transmitter Ground (Common with Receiver Ground) | 1 |
| 24 | Rx4n | Receiver Inverted Data Output | 1 |
| 25 | Rx4p | Receiver Non-Inverted Data Output | |
| 26 | GND | Transmitter Ground (Common with Receiver Ground) | 1 |
| 27 | ModPrsl | Module Present | |
| 28 | IntL | Interrupt | |
| 29 | VccTx | 3.3V power supply transmitter | 2 |
| 30 | Vcc1 | 3.3V power supply | 2 |
| 31 | LPMODE | Low Power Mode | |
| 32 | GND | Transmitter Ground (Common with Receiver Ground) | 1 |
| 33 | Tx3p | Transmitter Non-Inverted Data Input | |
| 34 | Tx3n | Transmitter Inverted Data Output | |
| 35 | GND | Transmitter Ground (Common with Receiver Ground) | 1 |
| 36 | Tx1p | Transmitter Non-Inverted Data Input | |
| 37 | Tx1n | Transmitter Inverted Data Output | |
| 38 | GND | Transmitter Ground (Common with Receiver Ground) | 1 |

Notes:

1. GND is the symbol for signal and supply (power) common for QSFP28 modules. All are common within the QSFP28 module and all module voltages are referenced to this potential unless otherwise noted. Connect these directly to the host board signal common ground plane.
2. VccRx, Vcc1 and VccTx are the receiving and transmission power suppliers and shall be applied concurrently. Recommended host board power supply filtering is shown below. Vcc Rx, Vcc1 and Vcc Tx may be internally connected within the QSFP28 transceiver module in any combination. The connector pins are each rated for a maximum current of 500mA.

V. Electrical Characteristics

The following electrical characteristics are defined over the Recommended Operating Environment unless otherwise specified.

| Parameter | Symbol | Min. | Typ. | Max | Unit | Notes |
|--------------------------------------|---------|---------|------|----------|------|-------|
| Power Consumption | p | | | 3.5 | W | |
| Supply Current | Icc | | | 1060 | mA | |
| Transmitter | | | | | | |
| Single-ended Input Voltage Tolerance | Vcc | -0.3 | | 4.0 | V | |
| Differential Input Voltage Swing | Vin,pp | 180 | | 1000 | mVpp | |
| Differential Input Impedance | Zin | 90 | 100 | 110 | Ohm | 1 |
| Transmit Disable Assert Time | | | | 10 | us | |
| Transmit Disable Voltage | Vdis | Vcc-1.3 | | Vcc | V | |
| Transmit Enable Voltage | Ven | Vee | | Vee +0.8 | V | 2 |
| Receiver | | | | | | |
| Differential Output Voltage Swing | Vout,pp | 300 | | 850 | mVpp | |
| Differential Output Impedance | Zout | 90 | 100 | 110 | Ohm | 3 |
| Data output rise/fall time | Tr/Tf | 28 | | | ps | 4 |
| LOS Assert Voltage | VlosH | Vcc-1.3 | | Vcc | V | 5 |
| LOS De-assert Voltage | VlosL | Vee | | Vee +0.8 | V | 5 |

Notes:

1. Connected directly to TX data input pins. AC coupled thereafter.
2. Or open circuit.
3. Input 100 ohms differential termination.
4. These are unfiltered 20-80% values.
5. Loss of Signal is LVTTTL. Logic 0 indicates normal operation; logic 1 indicates no signal detected.

VI. Optical Characteristics

The following optical characteristics are defined over the Recommended Operating Environment unless otherwise specified.

| Parameter | Symbol | Min. | Typical | Max | Unit | Notes |
|--|---------|------------------------------------|----------|---------|------|-------|
| Transmitter | | | | | | |
| Lane wavelength (range) | L0 | 1294.53 | 1295.56 | 1296.59 | nm | |
| | L1 | 1299.02 | 1300.05 | 1301.09 | nm | |
| | L2 | 1303.54 | 1304.58 | 1305.63 | nm | |
| | L3 | 1308.09 | 1309.14 | 1310.09 | nm | |
| Signaling rate, each lane | | | 25.78125 | | GBd | |
| Side-mode suppression ratio | SMSR | 30 | | | | |
| Total launch power | | | | 10.5 | dBm | |
| Average launch power, each lane | Pavg | -4.3 | | 4.5 | dBm | |
| Extinction Ratio | ER | 4 | | | dB | |
| Transmitter and Dispersion Penalty, each lane | TDP | | | 2.2 | dB | |
| OMA minus TDP, each lane | OMA-TDP | -2.3 | | | dBm | |
| Average launch power of OFF transmitter, each lane | | | | -30 | dBm | |
| Transmitter reflectance | | | | -12 | dB | |
| Transmitter eye mask {X1, X2,X3, Y1, Y2, Y3} | | {0.25, 0.4, 0.45, 0.25, 0.28, 0.4} | | | | |
| Receiver | | | | | | |
| Signaling rate, each lane | | | 25.78125 | | GBd | |
| Receiver Sensitivity per lane | Rsen | | | -10.6 | dBm | 1 |
| Input Saturation Power (overload) | Psat | | | 4.5 | dBm | |
| LOS Assert | LOSA | -30 | | | dBm | |
| LOS De-assert | LOSD | | | -12 | | |

| | | | | | | |
|----------------------|----|-----|--|-----|----|--|
| Receiver reflectance | Rr | | | -26 | | |
| LOS Hysteresis | | 0.5 | | 4 | dB | |

Notes:

1. Measured with a PRBS 231-1 test pattern, @25.78Gb/s, BER<10⁻¹².

VII. Digital Diagnostic Functions

The following digital diagnostic characteristics are defined over the normal operating conditions unless otherwise specified.

| Parameter | Symbol | Min. | Max | Unit | Notes |
|---------------------------------------|----------|-------|------|------|----------------------|
| Temperature monitor absolute error | DMI_Temp | -3 | 3 | °C | Over operating temp |
| Supply voltage monitor absolute error | DMI_VCC | -0.15 | 0.15 | V | Full operating range |
| RX power monitor absolute error | DMI_RX | -3 | 3 | dB | |
| Bias current monitor | DMI_bias | -10% | 10% | mA | |
| TX power monitor absolute error | DMI_TX | -3 | 3 | dB | |

VIII. Mechanical Dimensions

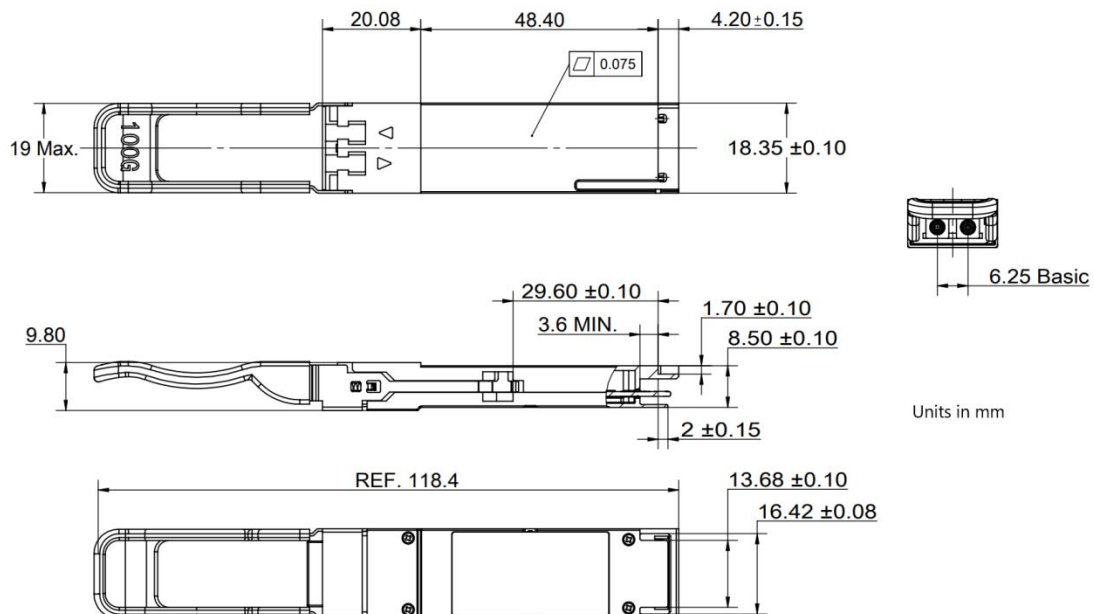

Figure2. Mechanical Outline

IX. Revision History

| Version No. | Initiated | Revised contents | Release Date |
|-------------|------------|-----------------------|--------------|
| V1.0 | Andy Zhang | Preliminary datasheet | 2018-09-20 |
| | | | |

X. Contact us

Walsun Optics Technology Co., Ltd

2-5# Tongfufu Industrial Zone, Aiqun Road, Shiyan Street, Baoan District, Shenzhen, China

T. +86 0755-23007456

F. +86 0755-23007451

E. sales@walsun.com

H. www.walsun.com

PC. 518108